

DIN-Rail EMC/RFI Filter with Minimum Leakage Current



- Compact state-of-the-art filter concept
- Light weight plastic enclosure design
- Minimized filter leakage current
- Hinged safety covers
- Revolutionary embedded filter terminals
- Chassis or DIN-rail mounting option
- Selectable performance level
- Environmental friendly design without potting compound



Performance indicators

Attenuation performance



Rated current [A]

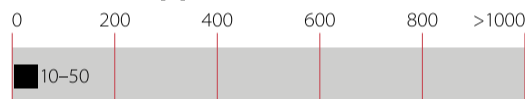

Approvals & Compliances



Design protected by European patent (EP 1727280)

Features and Benefits

- Two different mounting versions: FN 3025 for chassis mounting and FN3026 for DIN rail mounting
- Two different performance levels (L types, P types)
- A plastic housing and a metal ground plate are cleverly combined to get the lowest possible product weight without compromising EMC behavior
- The embedded jump-terminal system from Schaffner guarantees user-friendly handling as well as fast and reliable electrical connection
- Captive hinged protective covers contribute to overall safety by offering protection against unintended contact with live conductors. They are included in the standard delivery package without causing extra cost
- Very low leakage current values make these filter ranges ideally suitable for use in Japanese electricity networks as well as in applications which set value on safety and reliability

Technical Specifications

Maximum continuous operating voltage	3x 520/300 VAC
Operating frequency	DC to 60 Hz
Rated currents	10 to 50 A @ 50°C
High potential test voltage	P → E 2000 VAC for 2 sec (HL types) P → E 3000 VDC for 2 sec (HP types) P → P 2250 VDC for 2 sec
Protection category	IP 00 (protection according to VBG 4)
Overload capability	4x rated current at switch on, 1.5x rated current for 1 minute, once per hour
Temperature range (operation and storage)	-25°C to +100°C (25/100/21)
Flammability corresponding to	UL 94 V-2 or better
Design corresponding to	UL 1283, CSA 22.2 No. 8 1986, IEC/EN 60939
MTBF @ 50°C/400 V (Mil-HB-217F)	>200,000 hours

Typical Applications

- Applications with the requirement for extremely compact filter solutions
- Applications with tough leakage current requirements or sensitive earth leakage detectors
- Applications with insufficient internal filtering or moderate interference levels
- Automation equipment
- Motor drives and servo drives with short motor cables
- Applications including stepping motors
- Semiconductor manufacturing equipment
- Three-phase power supplies
- Medical equipment (not patient-coupled)

Typical electrical schematic

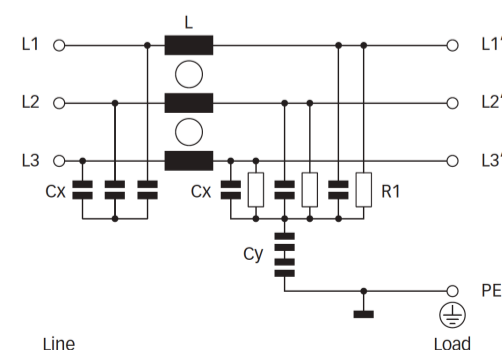

Filter Selection Table

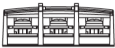
Filter	Rated current @ 50°C (40°C)	Typical drive power rating*	Leakage current** @ 520 VAC/50 Hz	Power loss @ 25°C/50 Hz	Input/Output connections 	Weight [kg]
	[A]	[kW]	[mA]	[W]		
FN 3025 HL-10-71	10 (10.7)	5.5	0.1	4.8	-71	0.52
FN 3025 HL-20-71	20 (21.4)	11	0.1	6.2	-71	0.52
FN 3025 HL-30-71	30 (32.1)	18.5	0.1	7.0	-71	0.54
FN 3025 HL-40-71	40 (43.8)	25	0.1	8.5	-71	0.63
FN 3025 HL-50-72	50 (53.5)	30	0.1	10.5	-72	0.93
FN 3025 HP-10-71	10 (10.7)	5.5	0.4	4.8	-71	0.52
FN 3025 HP-20-71	20 (21.4)	11	0.4	6.2	-71	0.52
FN 3025 HP-30-71	30 (32.1)	18.5	0.4	7.0	-71	0.54
FN 3025 HP-40-71	40 (43.8)	25	0.4	8.5	-71	0.63
FN 3025 HP-50-72	50 (53.5)	30	0.4	10.5	-72	0.93
FN 3026 HL-10-71	10 (10.7)	5.5	0.1	4.8	-71	0.56
FN 3026 HL-20-71	20 (21.4)	11	0.1	6.2	-71	0.56
FN 3026 HL-30-71	30 (32.1)	18.5	0.1	7.0	-71	0.58
FN 3026 HL-40-71	40 (43.8)	25	0.1	8.5	-71	0.74
FN 3026 HL-50-72	50 (53.5)	30	0.1	10.5	-72	0.98
FN 3026 HP-10-71	10 (10.7)	5.5	0.4	4.8	-71	0.56
FN 3026 HP-20-71	20 (21.4)	11	0.4	6.2	-71	0.56
FN 3026 HP-30-71	30 (32.1)	18.5	0.4	7.0	-71	0.58
FN 3026 HP-40-71	40 (43.8)	25	0.4	8.5	-71	0.74
FN 3026 HP-50-72	50 (53.5)	30	0.4	10.5	-72	0.98

* Calculated at rated current, 480 VAC and cos phi=0.8. The exact value depends upon the efficiency of the drive, the motor and the entire application.

** Standardized calculated leakage current acc. IEC60939 under normal operating conditions.

Typical Filter Attenuation

Per CISPR 17; A=50 Ω/50 Ω sym; B=50 Ω/50 Ω asym; C=0.1 Ω/100 Ω sym; D=100 Ω/0.1 Ω sym

10 and 20 A HL types

10 and 20 A HP types

30 to 50 A HL types

30 to 50 A HP types

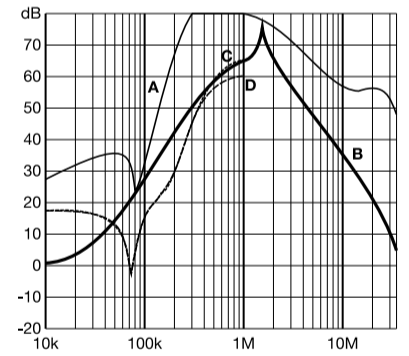
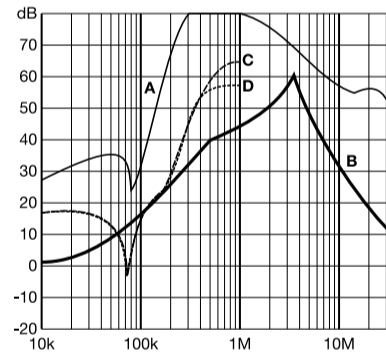
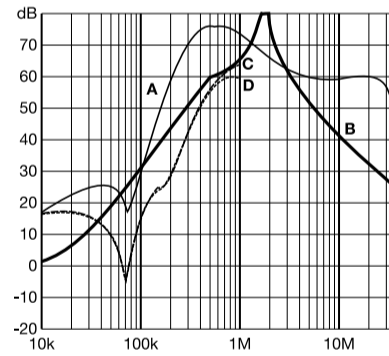
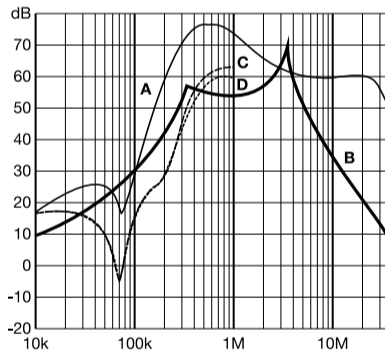

Installation

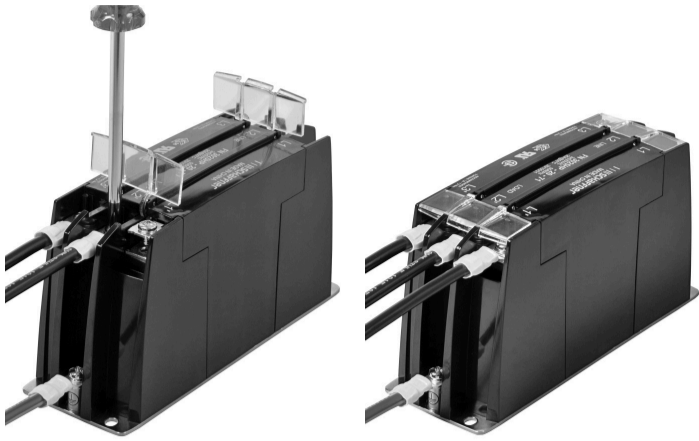

FN 3025/FN 3026 are delivered with closed plastic covers and unfastened terminals. To install the filter please proceed as follows:

- Mount the filter on a metal surface with four screws or snap it onto a TS 35 DIN- rail.
- First connect the green/yellow wire to the earth stud of the filter.
- Gently lift the two hinged plastic covers.
- Connect phase wires with cable lugs by pushing down and tightening the screws.
- Please note the torque recommendation on top of the filter.
- Push the covers back into their locked position to finish the filter installation.

Mechanical Data

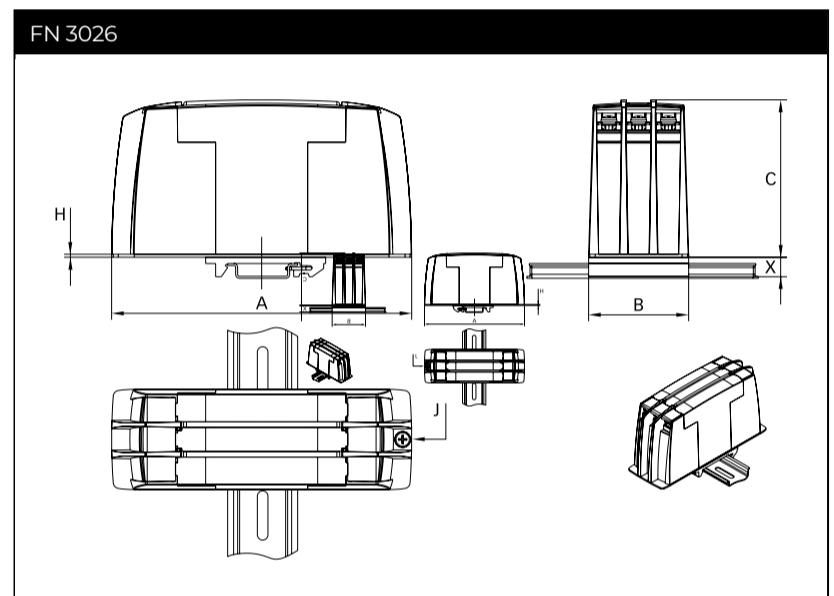
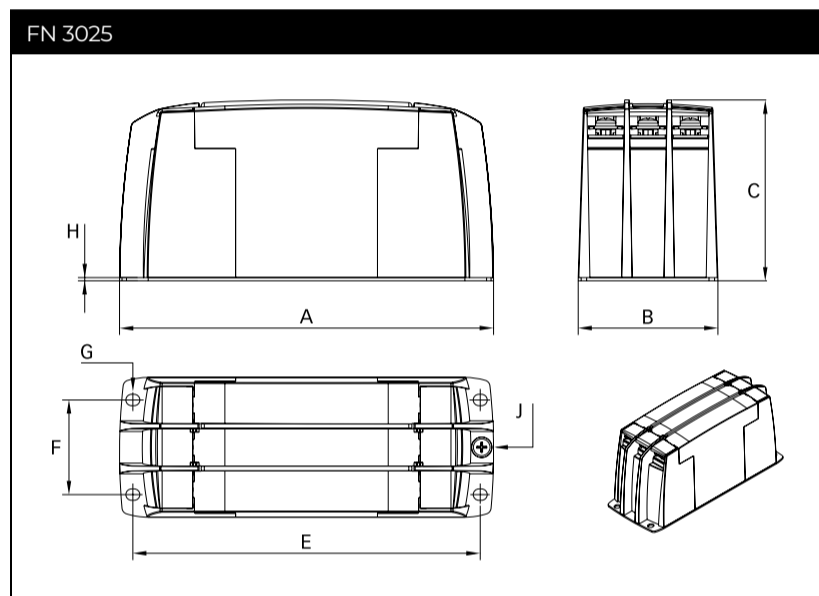

Dimensions





50

	FN 3025					FN 3026				
	10 A	20 A	30 A	40 A	50 A	10 A	20 A	30 A	40 A	50 A
A	150	150	150	150	177	150	150	150	150	177
B	50	50	50	50	65	50	50	50	50	65
C	78	78	78	78	84	78	78	78	78	84
E	140	140	140	140	162					
F	32	32	32	32	44					
G	4.3 x 5.5	4.3 x 5.5	4.3 x 5.5	4.3 x 5.5	5.3 x 6.5					
H	1.5	1.5	1.5	1.5	1.5	1.5	1.5	1.5	1.5	1.5
J	M4	M4	M4	M4	M5	M4	M4	M4	M4	M5
X						9.7	9.7	9.7	9.7	9.7

All dimensions in mm; 1 inch = 25.4 mm

Tolerances according: ISO 2768-m/EN 22768-m

Filter Input/Output Connector Cross Sections

	-71 (10 A)	-71 (20 A)	-71 (30 A and 40 A)	-72 (50 A)
				
Flex wire	1.3-2.5 mm ²	4-6 mm ²	8-10 mm ²	16-20 mm ²
AWG type wire	AWG 16-AWG 13	AWG 12-AWG 10	AWG 8-AWG 7	AWG 5-AWG 4
Ring/fork lug (W/d)*	max. 11 mm (9.5 mm)/ min. Ø4.3 mm**	max. 11 mm (9.5 mm)/ min. Ø4.3 mm**	max. 11 mm (9.5 mm)/ min. Ø4.3 mm**	max. 16.5 mm (15 mm)/ min. Ø5.3 mm**
Recommended torque	1.0-1.2 Nm	1.0-1.2 Nm	1.0-1.2 Nm	1.9-2.2 Nm

* Schaffner recommends the use of insulated and UL-recognized ring lugs or fork lugs of the appropriate size.

** Specification in () relates to earth connector.

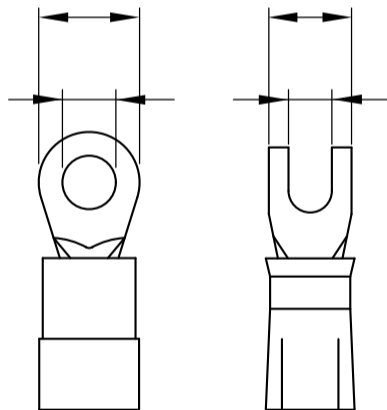
Please visit www.schaffner.com to find more details on filter connectors.

Headquarters, Global Innovation and Development

Switzerland

Schaffner Holding AG

Industrie Nord
Nordstrasse 11e
4542
Luterbach
+41 32 681 66 26
info@schaffner.com

Sales and Application Centers

China

Schaffner EMC Ltd. Shanghai

T20-3 C, No 565 Chuangye Road, Pudong district
201201
Shanghai
+86 2138139500
cschina@schaffner.com

Finland

Schaffner Oy

Sauvonrinne 19 H
8500
Lohja
+358 50 468 7284
finlandsales@schaffner.com

France

Schaffner EMC S.A.S.

16-20 Rue Louis Rameau
95875
Bezons
+33 1 34 34 30 60
francesales@schaffner.com

Germany

Schaffner Deutschland GmbH

Schoemperlenstrasse 12B
76185
Karlsruhe
+49 721 56910
germanysales@schaffner.com

India

Schaffner India Pvt. Ltd

Regus World Trade Centre
WTC, 22nd Floor Unit No 2238, Brigade Gateway Campus, 26/1, Dr. Rajkumar Road Malleshwaram (W)
560055
Bangalore
+91 8067935355
indiasales@schaffner.com

Italy

Schaffner EMC S.r.l.

Via Ticino, 30
20900
Monza (MB)
+39 039 21 41 070
italysales@schaffner.com

Japan

Schaffner EMC K.K.

ISM Sangenjaya 7F
1-32-12 Kamiuma, Setagaya-ku
154-0011
Tokyo
+81 3 5712 3650
japansales@schaffner.com

Singapore

Schaffner EMC Pte Ltd.

Blk 3015A Ubi Road 1, #05-09, Kampong Ubi Industrial Estate
408705
Singapore
+65 63773283
singaporesales@schaffner.com

Spain

Schaffner EMC España

Calle Caléndula 93, Miniparc III, Edificio E El Soto de Moraleja, Alcobendas
28109
Madrid
+34 917 912 900
spainsales@schaffner.com

Sweden

Schaffner EMC AB

Östermalmstrorg 1
114 42
Stockholm
+46 8 5050 2425
swedensales@schaffner.com

Switzerland

Schaffner EMV AG

Industrie Nord
Nordstrasse 11e
4542
Luterbach
+41 32 681 66 26
switzerlandsales@schaffner.com

Taiwan

Schaffner EMV Ltd.

U-Town
20 Floor-2, No 97, Section 1, XinTai 5th Road, XiZhi District
22175
New Taipei City
+886 226975500
taiwansales@schaffner.com

Thailand

Schaffner EMC Co. Ltd.

Sathorn Square Tower
Room 3780, 37FL, 98 North-Sathorn Rd, Silom, Bangrak
10500
Bangkok
+66 621056397
thailandsales@schaffner.com

United Kingdom

Schaffner Ltd.

1, Oakmede Place
Terrace Road
RG42 4JF
Binfield
+44 118 9770070
uksales@schaffner.com

United States

Schaffner EMC Inc.

52 Mayfield Avenue
Edison, New Jersey
+1 732 225 9533
usasales@schaffner.com

To find your local partner within Schaffner's global network schaffner.com

© 2022 Schaffner Group

The content of this document has been carefully checked and understood. However, neither Schaffner nor its subsidiaries assume any liability whatsoever for any errors or inaccuracies of this document and the consequences thereof. Published specifications are subject to change without notice. Product suitability for any area of application must ultimately be determined by the customer. In all cases, products must never be operated outside their published specifications. Schaffner does not guarantee the availability of all published products. This disclaimer shall be governed by substantive Swiss law and resulting disputes shall be settled by the courts at the place of business of Schaffner Holding AG. Latest publications and a complete disclaimer can be downloaded from the Schaffner website. All trademarks recognized.