

FN2660-15-103-C0909

SAP Code: 821808

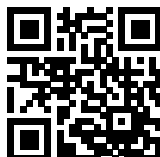

- Chassis mount
- 15 A IEC inlet EMC filter with push-in terminals
- 1 Phase

[Buy article now](#)

Family Technical Specifications

Operating frequency	DC to 60 Hz
Climatic category	40/085/21 acc. IEC60068-1
Surge withstand	2 kV Ph-Ph / 4 kV Ph-PE (Level 4)
High potential test voltage	P → N 1500 VDC for 2 sec* P/N → PE 2500 VDC for 2 sec*
Rated operating voltage	250 VAC
Altitude	Derating above 2000 m
Certified to	UL 60939-3, IEC/EN 60939, GB/T 15287
MTBF	> 300,000 h
Protection category	IP00 / IP20 for -103 terminal
Protection category	2 acc. IEC 60664-1
Rated currents	15
Vibration and shock	3M12 acc. IEC 60721-3-3
Overtoltage category	II acc. IEC 60664-1
Temperature range (operation and storage)	-40°C to +85°C (with derating >40°C)
Overload capability	1.5 x rated current for 1 minute once per hour
Cooling	Natural cooling AN
Flammability corresponding to	Plastic Material: UL 94 V0 Laces for -07 version: UL 94 VW1

* High potential test voltage: Repetition with max. 80% of specified values

Features and Benefits

- FN2640 / FN2660 series fits perfectly within 1HU height for rack mount applications
- The filters are built to fit perfectly to datacenter and audio video equipment
- The shape allows convenient and space-saving installation
- Fulfills the requirements in IEC/EN 62040-1 - Uninterruptible power systems (UPS)
- Fulfills the requirements in IEC 62368-1 - Audio/Video, Information and Communication Technology Equipment
- Fulfills the requirements in IEC/EN 60335-1 - Household and similar appliances

Typical Applications

- Robotics, collaborative robots, autonomous machines
- Audio and video equipment
- UPS - Uninterruptible power supplies

Typical electrical schematic

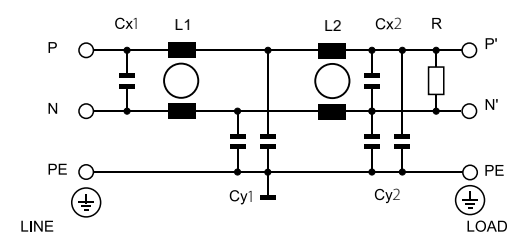

General Specification

Voltage AC	250 (Volt)
Nominal Frequency	50
Rated Current @ambient	15
Ambient temperature [°C]	40

Electric Specification

Leakage current (IEC60939) [mA]	0.35
Input terminal	27 - IEC-plug
Output terminal	103 - push-in terminal
Resistance	680 (Kilohm)

Attenuation Specification

CM attenuation @ 150kHz [dB]	50 (Decibels)
DM attenuation @ 150kHz [dB]	38 (Decibels)
Inductance L1 [μH]	4 (Millihenry)
Inductance L2 [μH]	4 (Millihenry)
Capacitance Cx1 [μF]	1 (Microfarad)
Capacitance Cx2 [μF]	0.47 (Microfarad)
Capacitance Cy1 [nF]	2.2 (Nanofarad)
Capacitance Cy2 [nF]	2.2 (Nanofarad)

Attenuation graph

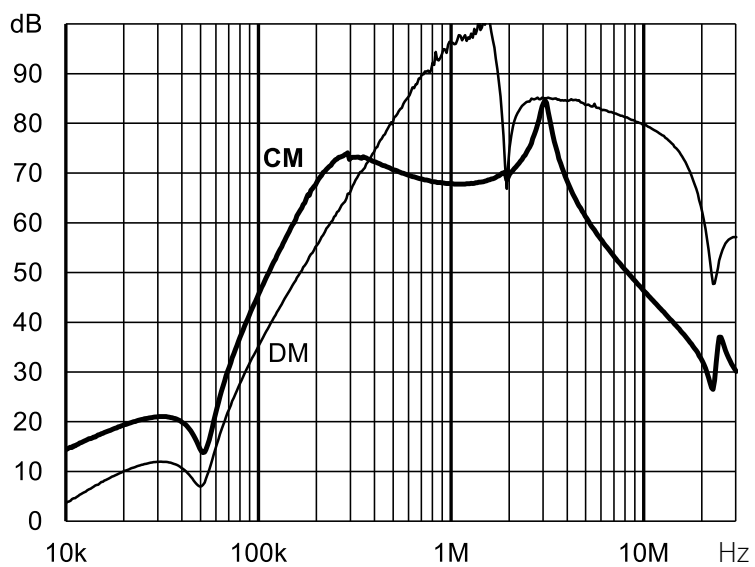

Mechanic Specification

Length [mm]	184.7
Width [mm]	73
Height [mm]	35
Volume [cm ³]	472 (Cubic Centimeter)
NetWeight [g]	484 (Gram)
Power Loss [W]	8.2 (Watt)

Schaffner schemes

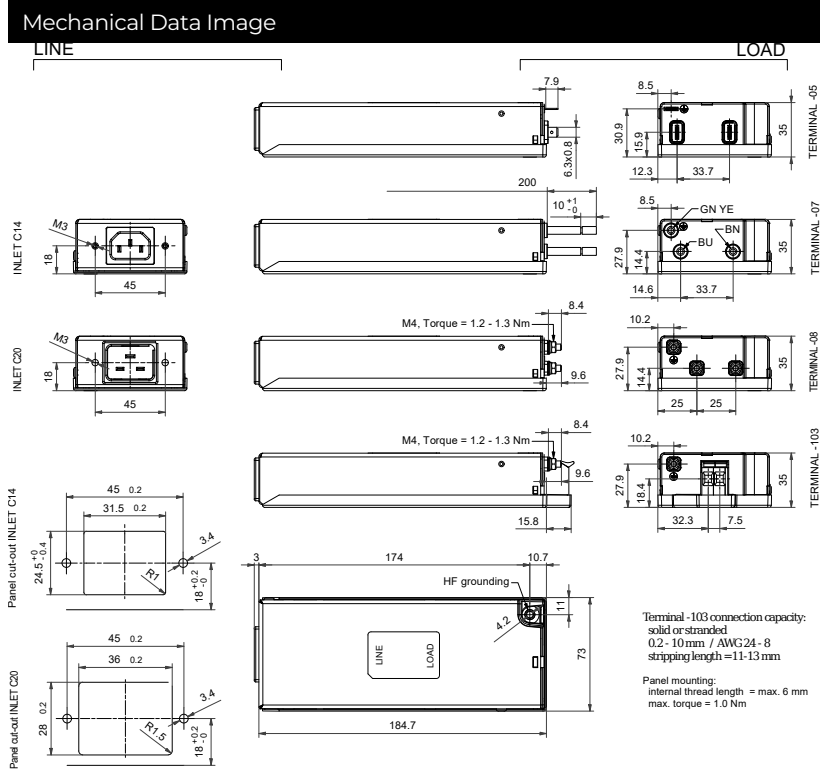

Dimensions