

# FN2500-15-05-C13

SAP Code: 821775

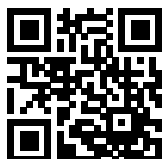

- Chassis mount
- 15 A EMC filter with fast-ons
- 1 Phase

[Buy article now](#)

## Family Technical Specifications

<b>Rated operating voltage</b>	277 VAC / 400 VDC (CQC: 250 VAC / 250 VDC)
<b>Operating frequency</b>	DC to 60 Hz
<b>Protection category</b>	IP00 / IP20 for -103 terminals
<b>Pollution degree</b>	2 acc. IEC 60664-1
<b>Vibration and shock</b>	3M12 acc. IEC 60721-3-3
<b>Oversvoltage category</b>	II acc. IEC 60664-1
<b>Temperature range (operation and storage)</b>	FN2500: -40°C to +100°C (with derating >50°C) FN2520: -40°C to +85°C (with derating >50°C)
<b>Cooling</b>	Natural cooling AN
<b>Climatic category</b>	FN2500: 40/100/21 acc. IEC60068-1 FN2520: 40/085/21 acc. IEC60068-1 FN2520: 40/085/21 acc. IEC60068-1
<b>Flammability corresponding to</b>	Plastic material: UL 94 V0 Laces for -07 version: UL 94 VW1
<b>Rated currents</b>	15
<b>Surge withstand</b>	2 kV Ph-Ph / 4 kV Ph-PE (Level 4)
<b>High potential test voltage</b>	P(DC+) → N(DC-) 1500 VDC for 2 sec* P(DC+)/N(DC-) → PE 2500 VDC for 2 sec*
<b>Overload capability</b>	1.5 x rated current for 1 minute once per hour
<b>Altitude</b>	Derating above 2000 m
<b>Certified to</b>	UL/IEC 60939-3, CSA 22.2 No. 8-13, GB/T 15287
<b>MTBF</b>	> 300,000 h

\* High potential test voltage: Repetition with max. 80% of specified values

## Approvals & Compliances



Certifications FN2520 pending

## Features and Benefits

- FN2500 / FN2520 series fits perfectly within 1HU height for rack mount
- The filters are built to perform perfectly in datacenter and audio video equipment
- The shape allows convenient and space-saving installation
- Fulfills the requirements in IEC/EN 62040-1 - Uninterruptible power systems (UPS)
- Fulfills the requirements in IEC 62368-1 - Audio/Video, Information and Communication Technology Equipment
- Fulfills the requirements in IEC/EN 60335-1 - Household and similar appliances

## Typical Applications

- Datacenter (at 400 VDC)
- Building technology with DC power distribution
- Robotics, collaborative robots, autonomous machines
- Audio and video equipment
- UPS - Uninterruptible power supplies

## Typical electrical schematic

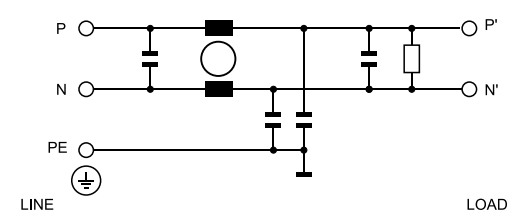

## General Specification

Voltage AC	277 (Volt)
Nominal Frequency	50
Rated Current @ambient	15
Ambient temperature [°C]	50

## Electric Specification

Leakage current (IEC60939) [mA]	0.87
Input terminal	05 - faston 6.3x0.8
Output terminal	05 - faston 6.3x0.8
Resistance	680 (Kiloohm)

## Attenuation Specification

CM attenuation @ 150kHz [dB]	38 (Decibels)
DM attenuation @ 150kHz [dB]	32 (Decibels)
Inductance L1 [μH]	4 (Millihenry)
Capacitance Cx1 [μF]	1 (Microfarad)
Capacitance Cx2 [μF]	0.47 (Microfarad)
Capacitance Cy1 [nF]	10 (Nanofarad)

### Attenuation graph

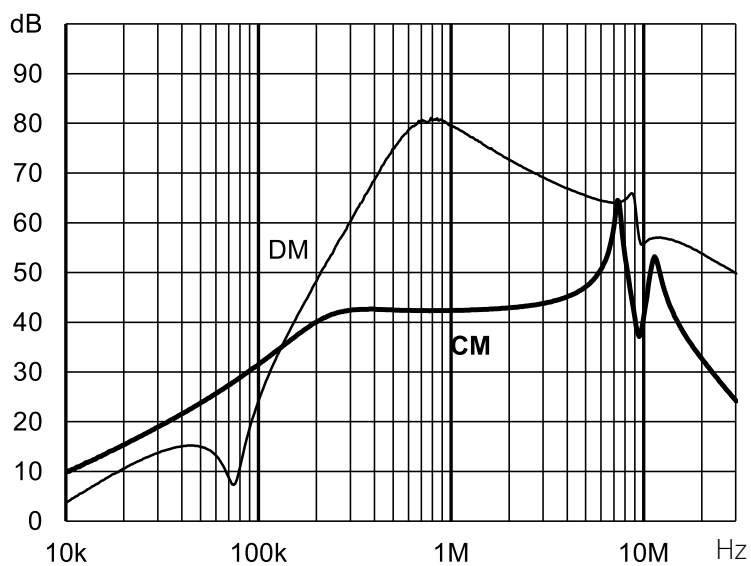

## Mechanic Specification

Length [mm]	97.7
Width [mm]	59
Height [mm]	35
Volume [cm <sup>3</sup> ]	202 (Cubic Centimeter)
NetWeight [g]	240 (Gram)
Power Loss [W]	6.4 (Watt)

## Schaffner schemes

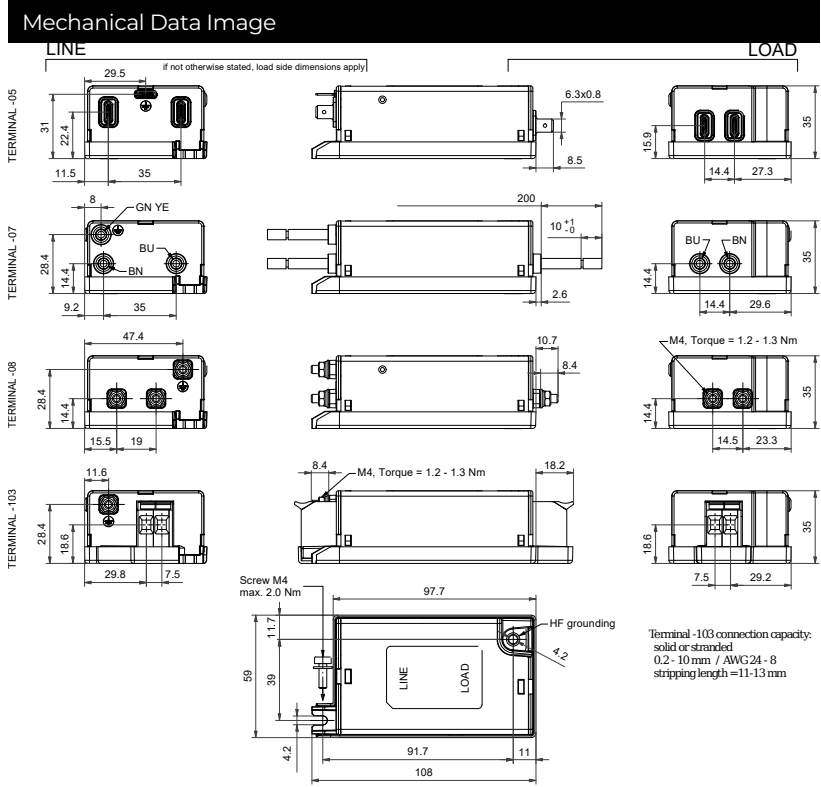

## Dimensions