

FN3100-300-99 801123

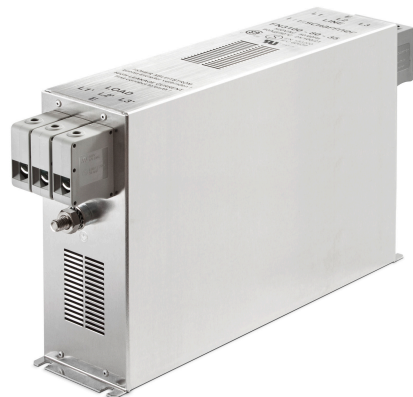

- Chassis mount
- 300 A EMC filter with bus bars
- 3 Phases

Buy article now

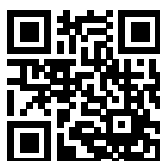

Approvals & Compliances



(FN3100 up to 150 A)

Features and Benefits

- High performance filter for mainly industrial motor drive applications with significant interference levels
- Attenuation performance for Class B compliance in applications comprising multiple motor drives (e.g. machine tool with up to 8 driving axes with ~10 to 20 m motor cable each)
- Broadband filter performance with low frequency attenuation down to 10 kHz for reliable suppression of conducted interference
- Slim book-style shape requiring minimum cabinet space and allowing convenient installation right beside the motor drive
- Touch-safe terminal blocks provide unsurpassed electrical safety and contacting cross section according to EN 60204-1 installation standard
- For even better filter specifications, please consider FN 3120 H series from Schaffner

Family Technical Specifications

Maximum continuous operating voltage	3x 520/300 VAC
Operating frequency	DC to 60 Hz
Temperature range (operation and storage)	-25°C to +100°C (25/100/21)
Flammability corresponding to	UL 94 V-2 or better
Design corresponding to	UL 1283, CSA 22.2 No. 8 1986, IEC/EN 60939
Rated currents	300
High potential test voltage	P → E 2750 VDC for 2 sec P → P 2250 VDC for 2 sec
Protection category	IP 20
Overload capability	4x rated current at switch on, 1.5x rated current for 1 minute, once per hour

Typical Applications

- Conventional motor drives with long motor cables and high interference levels
- Four quadrant motor drives and servo drives with energy regeneration mode (in combination with a suitable line reactor or LCL filter)
- Industrial applications comprising power conversion devices, such as machinery, machine tools and process automation equipment
- Uninterruptible power supplies (UPS)
- Converters for renewable energy generation
- Thyristor drives
- Elevators and cranes

Typical electrical schematic

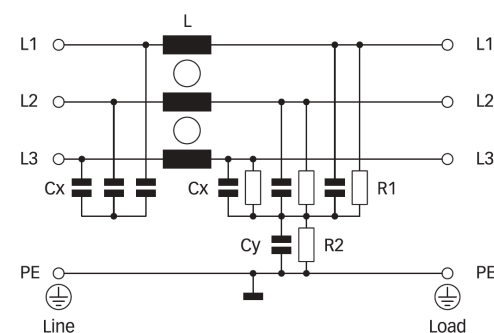

General Specification

Voltage AC	520 (Volt)
Nominal Frequency	50
Rated Current @ambient	300
Ambient temperature [°C]	50

Electric Specification

Leakage current (IEC60939) [mA]	10
Leakage current (Schaffner) [mA]	426
Input terminal	99 - special / busbar
Output terminal	99 - special / busbar

Attenuation Specification

CM attenuation @ 150kHz [dB]	65 (Decibels)
DM attenuation @ 150kHz [dB]	25 (Decibels)

Attenuation graph

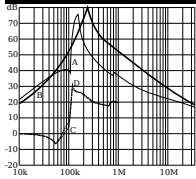

Mechanic Specification

Length [mm]	610
Width [mm]	200
Height [mm]	200
Volume [cm ³]	24400 (Cubic Centimeter)
NetWeight [kg]	13200 (Gram)
Power Loss [W]	54 (Watt)

Schaffner schemes

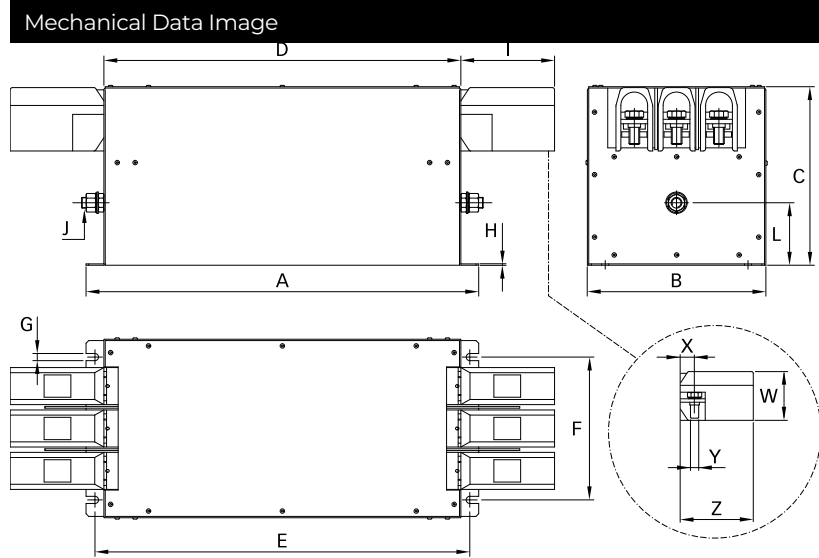

Dimensions

A [mm]	440
B [mm]	200
C [mm]	200
D [mm]	400
E [mm]	420
F [mm]	160
G [mm]	8
H [mm]	1.5
I [mm]	105
J [mm]	M12
K [mm]	70
L [mm]	71.5
X [mm]	~22
Y [mm]	M12
Z [mm]	~105